

## • Features

1. Chip material: AlGaInP
2. Emitted color: Amber
3. Lens appearance: Water Clear
4. Low power consumption
5. High efficiency
6. Versatile mounting on PC Poard
7. High reliability and long life
8. 3mm diameter package
9. RoHS compliant

## • Applications

1. Panel Indicator
2. Monitor
3. Audio Indicator
4. Computer
5. Circuit board

## • Package Dimensions

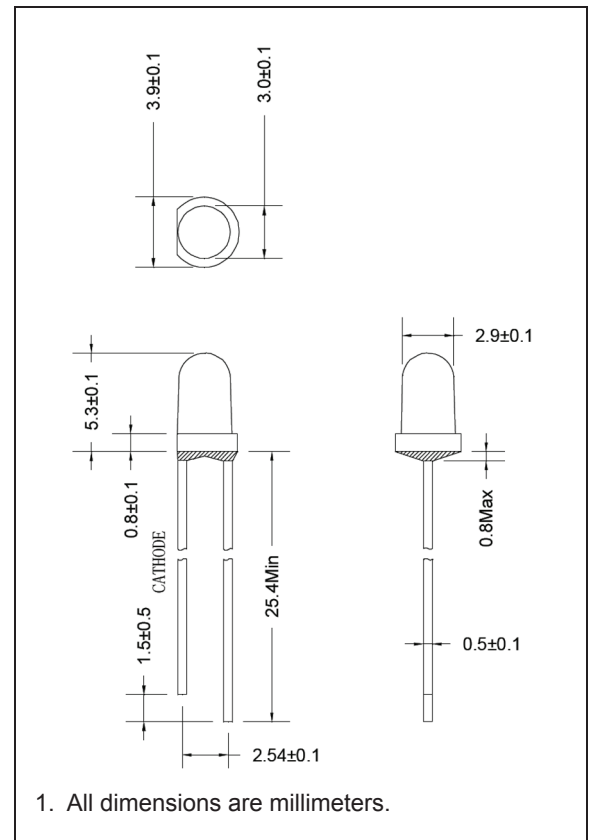

## • Absolute Maximum Ratings ( $T_a = 25^\circ \text{C}$ )

Parameter	Symbol	Rating	Unit
Power Dissipation	$P_D$	75	mW
Forward Current	$I_F$	30	mA
Peak Forward Current *	$I_P$	100	mA
Reverse Voltage ( $I_r=30\mu\text{A}$ )	$V_R$	5	V
Operating Temperature	$T_{OPR}$	-40 ~ 85	$^\circ\text{C}$
Storage Temperature	$T_{STG}$	-40 ~ 100	$^\circ\text{C}$
Soldering Temperature	$T_{SOL}$	260**	$^\circ\text{C}$

\* Condition for  $I_{FP}$  is pulse of 1/10 duty and 0.1 msec width.

\*\* for 5 seconds

• **Electrical and Optical Characteristics** ( $T_a = 25^\circ \text{C}$ )

Parameter	Symbol	Condition	Min.	Typ.	Max.	Unit
Forward Voltage	$V_F$	$I_F=20\text{mA}$	-	2.0	2.4	V
Reverse Current	$I_R$	$V_R=5\text{V}$	-	-	30	$\mu\text{A}$
Luminous Intensity	$I_V$	$I_F=20\text{mA}$	-	1800	-	mcd
Peak Wavelength	$\lambda_P$	$I_F=20\text{mA}$	-	591	-	nm
Dominant Wavelength	$\lambda_D$	$I_F=20\text{mA}$	-	589	-	nm
Spectral Bandwidth (50% of $I_V$ )	$\Delta\lambda$	$I_F=20\text{mA}$	-	20	-	nm
Viewing Angle	$2\theta_{1/2}$	$I_F=20\text{mA}$	-	24	-	deg

• **Typical Electro-optical Characteristic Curves**

