

• Features

1. Chip material: AlGaInP
2. Emitted color: Red
3. Lens appearance: Water Clear
4. Low power consumption
5. High efficiency
6. Versatile mounting on PC Poard
7. High reliability and long life
8. 3mm diameter package
9. RoHS compliant

• Applications

1. Panel Indicator
2. Monitor
3. Audio Indicator
4. Computer
5. Circuit board

• Package Dimensions

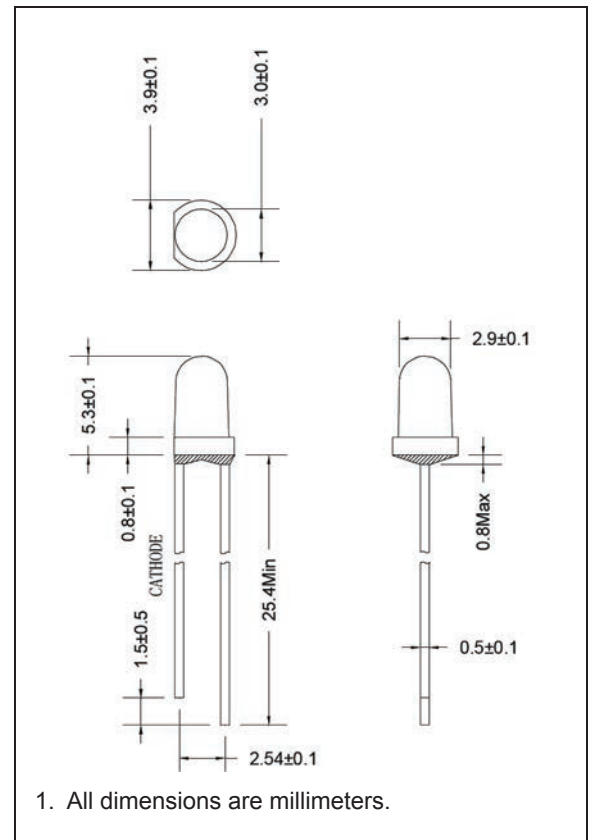

• Absolute Maximum Ratings ($T_a = 25^\circ \text{C}$)

Parameter	Symbol	Rating	Unit
Power Dissipation	P_D	75	mW
Forward Current	I_F	30	mA
Peak Forward Current *	I_P	100	mA
Reverse Voltage ($I_r=30\mu\text{A}$)	V_R	5	V
Operating Temperature	T_{OPR}	-40 ~ 85	$^\circ\text{C}$
Storage Temperature	T_{STG}	-40 ~ 100	$^\circ\text{C}$
Soldering Temperature	T_{SOL}	260**	$^\circ\text{C}$

* Condition for I_{FP} is pulse of 1/10 duty and 0.1 msec width.

** for 5 seconds

• **Electrical and Optical Characteristics** ($T_a = 25^\circ \text{C}$)

Parameter	Symbol	Condition	Min.	Typ.	Max.	Unit
Forward Voltage	V_F	$I_F=20\text{mA}$	-	2.0	2.5	V
Reverse Current	I_R	$V_R=5\text{V}$	-	-	30	μA
Luminous Intensity	I_V	$I_F=20\text{mA}$	-	700	-	mcd
Peak Wavelength	λ_P	$I_F=20\text{mA}$	-	632	-	nm
Dominant Wavelength	λ_D	$I_F=20\text{mA}$	-	624	-	nm
Spectral Bandwidth (50% of I_V)	$\Delta\lambda$	$I_F=20\text{mA}$	-	20	-	nm
Viewing Angle	$2\theta_{1/2}$	$I_F=20\text{mA}$	-	26	-	deg

• **Typical Electro-optical Characteristic Curves**

